



PRODUCT SPECIFICATION

The FHG series is designed for use in all levels of security facilities and high abuse applications.

Mounting

Mounts recessed in metal pan or gypsum ceiling with universal mounting brackets.

Housing

Die-formed cold rolled steel with seams welded and ground smooth. Stainless steel is also available.

Door

One piece, die formed cold rolled steel door with 14 gauge lens retainers and a full length welded pin piano hinge. Stainless steel available.

Finish

Polyester powder-coated after phosphate pretreatment for superior adhesion and corrosion resistance. Brushed stainless steel available.

Hardware

Recessed, stainless steel, tamper-proof fasteners.

Wiring

Access plate with two .875 in. diameter knockouts.

Certifications

UL Listed damp or wet location.

Job Name _____

Fixture Type _____

Catalog No. _____

Approval _____ Date _____

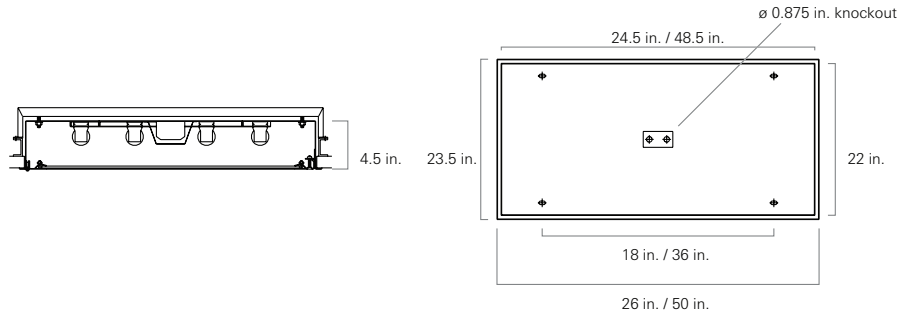
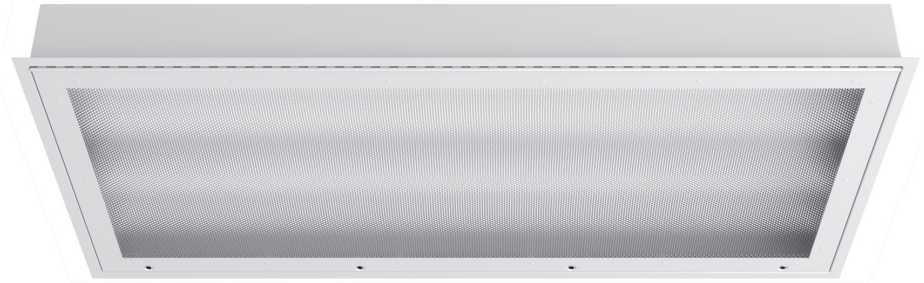

FHG	one	two	three	four	five	six	seven	eight	nine	ten	eleven	twelve
-----	-----	-----	-------	------	------	-----	-------	-------	------	-----	--------	--------

one Lamps (not included)

- 14 2 ft. 14 W T5
- 17 2 ft. 17 W T8
- 24 2 ft. 24 W T5 HO
- 4B 2 ft. 40 W T5 biax
- 28 4 ft. 28 W T5
- 32 4 ft. 32 W T8
- 54 4 ft. 54 W T5 HO

two Lamp Quantity

- 2 two
- 3 three
- 4 four
- 6 six

three Material Gauge

- N 18 gauge, minimum security
- D 16 gauge, medium security
- X 14 gauge, maximum security

four Material

- C Cold rolled steel
- S Stainless steel

five Finish

- R Brushed stainless steel
- W White

six Voltage

- 120 120 V, 60 Hz
- 277 277 V, 60 Hz
- 347 347 V, 60 Hz
- VAR Variable, 120-277 V, 50/60Hz

seven Ballast

- DM Dimming
- EL Electronic Instant Start, std T8
- PR Program Rapid Start, std T5, option T8

eight Internal Lens

- 53 .125 in. K12 prismatic acrylic
- 15 .156 in. K12 prismatic polycarbonate
- 16 .187 in. K12 prismatic polycarbonate
- 75 .156 in. C73 prismatic tempered glass
- 01 .005 in. UV absorbing overlay

nine External Lens

- 30 .187 in. clear polycarbonate
- 32 .250 in. clear polycarbonate
- 36 .375 in. clear polycarbonate
- 38 .500 in. clear polycarbonate
- 90 .187 in. clear tempered glass
- 92 .250 in. clear tempered glass
- 96 .375 in. clear tempered glass

ten Door Fasteners

- AP Stainless steel allen head with pin
- TP Stainless steel torx head with pin
- PH Phillips, non-security

eleven UL Listing

- D Damp Location
- W Wet Location

twelve Options

- 2C Two-circuit wired
- CU Canadian UL Listing
- E1 One lamp emergency ballast
- E2 Two lamp emergency ballast
- FH Fuse and holder
- NL Night light, for 7 W or 9 W PL bipin
- NL-LED Night light, LED
- IMS Integral Occ Sensor
- PF Plaster frame

Modifications are available to meet custom requirements.